

HP-100 MOTOR SERIES A -SERIES

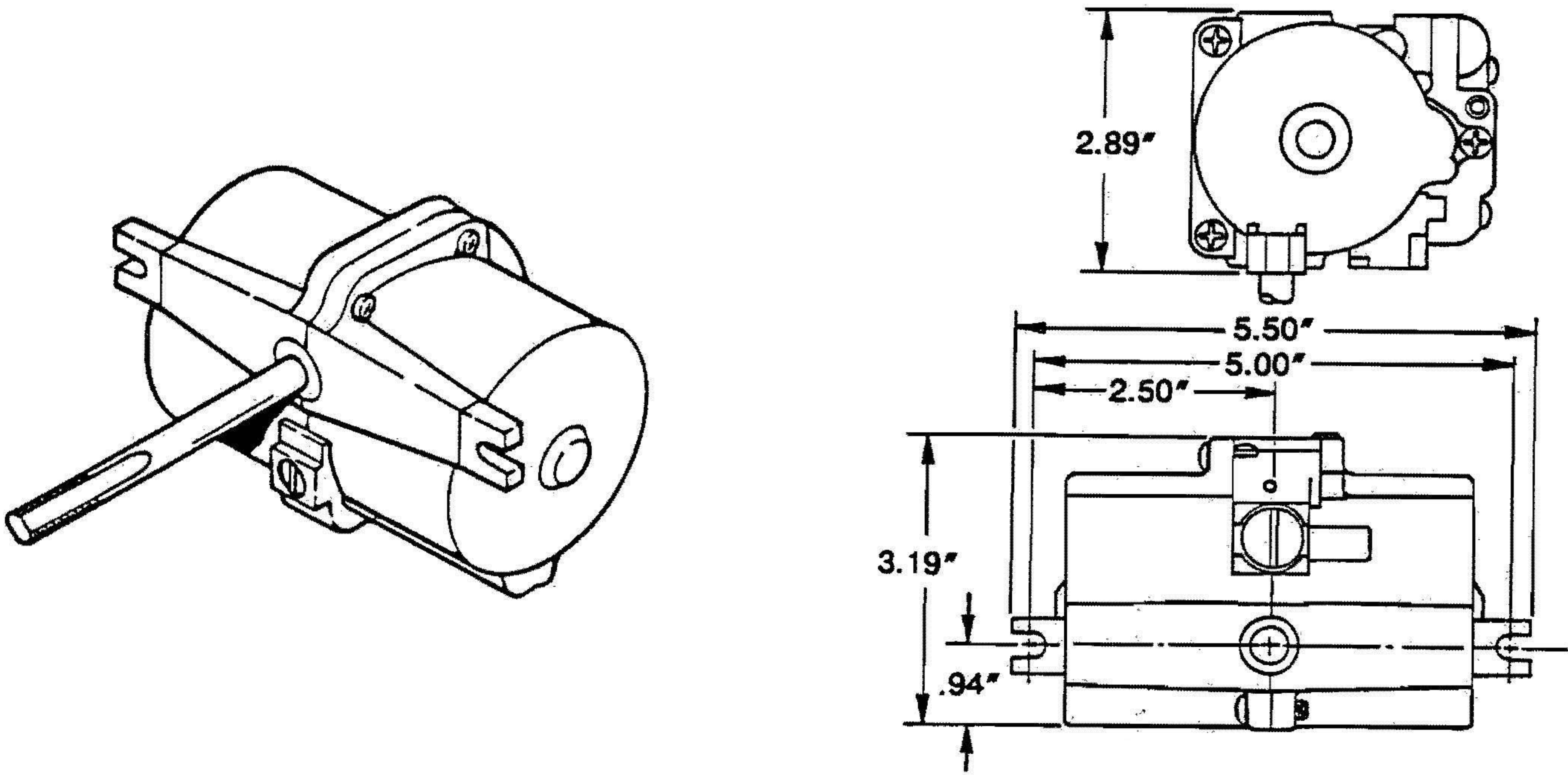

EXAMPLE - A10/09001/101

SERIES NUMBER	MOTOR	SWEEP RANGE
A1	HP-100	40 - 106 DEG.
A3	HP-125	50 - 105 DEG.
A4	HP-150	115 - 130 DEG.
A6	HP-130	50 - 106 DEG.
A7	HP-135	50 - 106 DEG.

AIR CONSUMPTION: 2.6 C.F.M. AT 100 P.S.I.

TORQUE: 230 IN. LBS. AT 100 P.S.I.

WEIGHT: 1.69 LBS. (APPROX.)

OPERATING PRESSURE: 30 TO 100 P.S.I.